

Silver Start Aircraft Batteries

Pure Lead Tin VRLA Monobloc Batteries





Pure Lead - Tin, Valve Regulated Lead Acid Monobloc

The "Silver Start" range of on-board, sealed maintenance-free Aircraft start batteries from HBL NIFE use Thin, Pure lead-tin plates for enhanced performance.

Features:

- Excellent starting capability: very high peak power
- Fast-charge capability: 100% recharge in 2hrs
- More flying hours: long life
- Operation in wide temperature range: -40°C to +50°C
- Safety inside the aircraft: non-spillable absorbed electrolyte design
- Delivered fully charged, ready-to-use: no commissioning at site
- Flame Retardant V0 grade Container and Cover: UL Approved

Conformance Standards

Silver Start batteries conform to the MIL 8565J and IEC 952-1 standards.

Connector type

MS 18093 / MS 3509

SS10060

Silver Start Aircraft Battery

Rating: 24V, 10Ah @ 1hr to end 20V

Weight: 13.0 Kgs (max)

Power Ratings at 23°C:

I_{pp} : 750 A

I_{pr} : 500 A

Dimensions (with box)

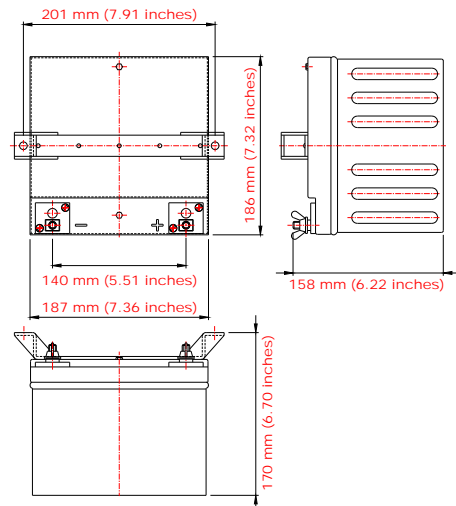

SS18060

Silver Start Aircraft Battery

Rating: 24V, 18Ah @ 1hr to end 20V

Weight: 21 Kgs (max)

Power Ratings at 23°C:

I_{pp} : 1250 A

I_{pr} : 700A



Dimensions (with box)

Format 1

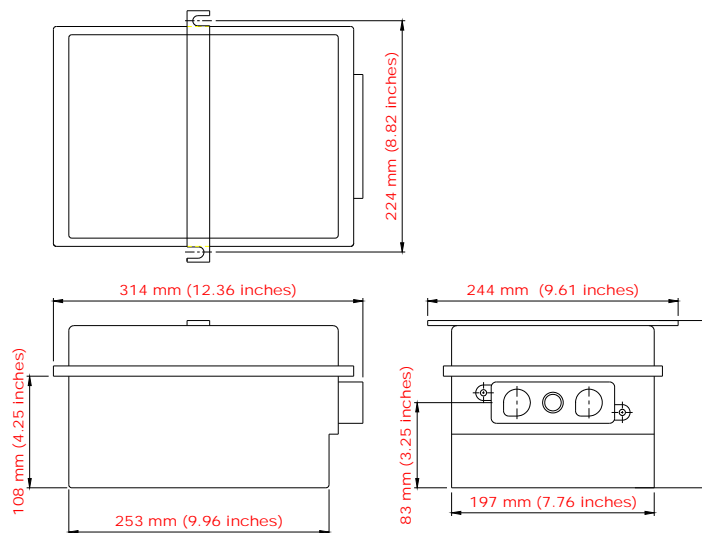

Format 2

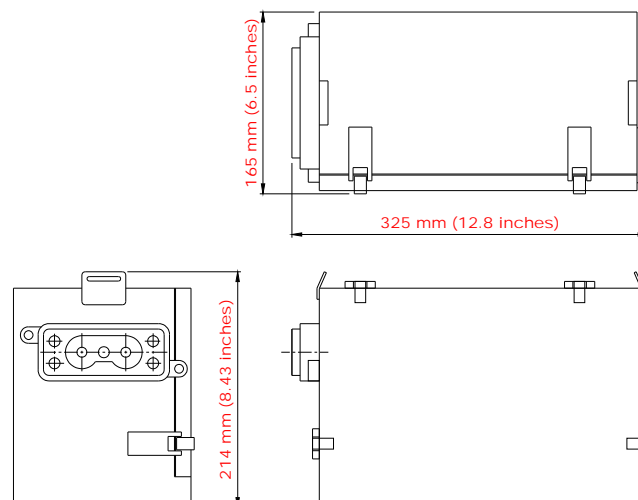



Dimensions (with box)

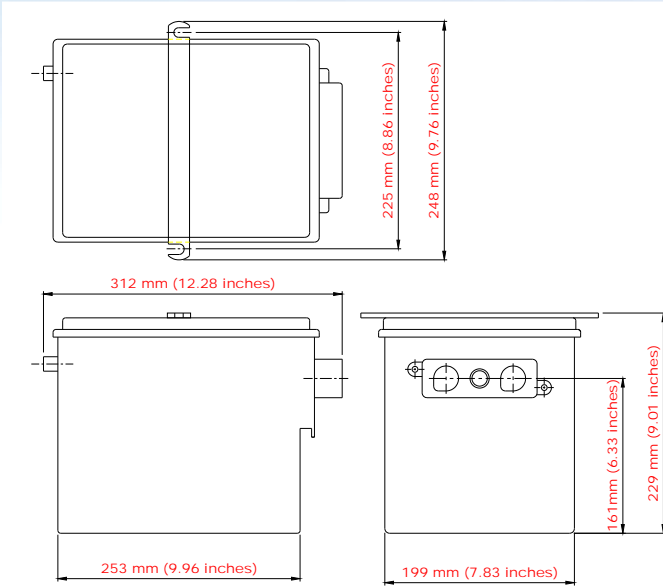

SS25060

Silver Start Aircraft Battery

Rating: 24V, 25Ah @ 1hr to end 20V

Weight: 27 Kgs (max)

Power Ratings at 23°C:

I_{pp} : 1400 A

I_{pr} : 800 A

SS42060

Silver Start Aircraft Battery

Rating: 24V, 42Ah @ 1hr to end 20V

Weight: 42 Kgs (max)

Power Ratings at 23°C:

I_{pp} : 1550 A

I_{pr} : 1200 A

Dimensions (with box)

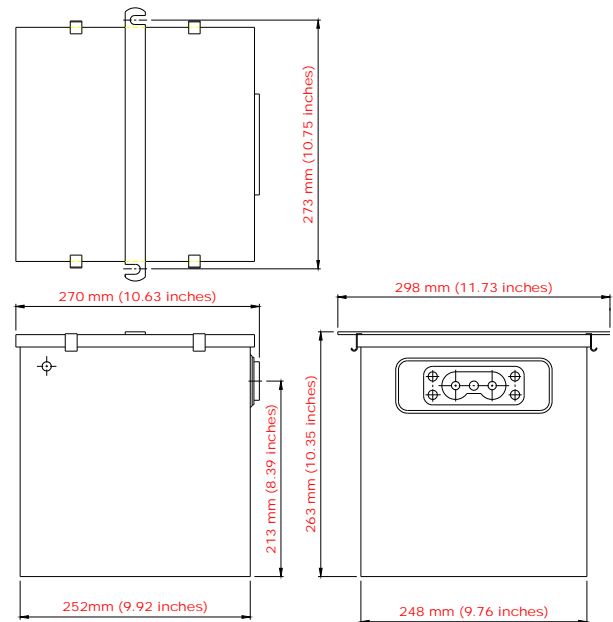

Pure Lead-Tin Aircraft Batteries Application Sheet

Model	Battery Type	Replaces	Aircraft Manufacturer	Aircraft Type
SS 10060	24V, 10Ah Sealed Lead Acid Battery	Gill G-243, Concorde CB24-11M	American General	AG-5/B Tiger
			Cessna	152, A152, 172, 172RG, 182,R182,TR182, 185, 188,T303, SN T30300001-T30300117
			Commander Aircraft Co	114AT, 114TC, 114B
			Mooney	SN 24-3155 & after, M-20K SN 25-1225 & after, M-20L PFM Mooney Porsche, M-20M TLS, M-20R
			New Piper Aircraft Inc.	PA28-161 WARRIOR III SN 28-16110 & UP, PA28-181 ARCHER III SN 28-90206 & UP, PA 32R-301 SARATOGA II TC SN 32-57001 & UP, PA 32R-301 SARATOGA II HP SN 32-46018 & UP, PA 46-350P MALIBU MIRAGE, PA-46 MALIBU, PA-46 350 MALIBU MIRAGE
			Partenavia	P-68C, TC, OBS
			Schweizer	300-C, CB
			Siai Marchetti	F-260, B
SS 18060	24V, 18Ah Sealed Lead Acid Battery	Hawker 18Ah (9750D0741, 9750-0740, 9750-0744	Avro	Chimunk T10
			British Aerospace	Bulldog T MK-1, Hawk, Hawk 100, Hawk 200, Hunter, Sea Harrier, Strike Master
SS 25060	24V, 25Ah Sealed Lead Acid Battery	Hawker 25Ah (9750E0640, 9750Y0662, 9750E0750, 9750W0640)	Fairchild Aircraft	26AT, SA226AT, SA226TC, SA227AT, SA227AC, SA227CC, SA227DC, SA227DD
			British Aerospace	Bae 146 100A/200A/300A AVRO 146-RJ70A/85A/100A
			British Aerospace /Raytheon	DH/HS 125 Series 1/3/400 BH-HS 125-600 Series HS 125-700 / Be 125-800 Series Hawker 800XP Series
			Westland Helicopter	EH-101 Series
			Jetstream Aircraft Ltd	3100 & 3200 Series

Pure Lead-Tin Aircraft Batteries Application Sheet

Model	Battery Type	Replaces	Aircraft Manufacturer	Aircraft Type
SS 42060	24V, 42Ah Sealed Lead Acid Battery	Concorde RG-380E/44 Hawker 9750W0370, Hawker 9750W0538, Gill G-6381E	Beech (Raytheon)	65-90, 65-A90, B90, C90, E90, F90, 99, A100, B100, 200, 300, B300, MU-300-10, 400, 400A, 400T, 2000 Series
			Cessna	208, 208B, 406, 425, 500, 501, 550, 551, S550, 560, 650
			Sabreliner	NA 265-20, -30, -40, -70, -80
			Sikorsky	S-76
			Kaman	K-1200
			Dassault	Falcon 20 Series, Falcon 200 Series
			Bell	204B, 205A, 205A-1, 212, 222, 222B, 222U, 412
			Bombardier Canadair	CL-600 Series
			Embrear Empresa	110 Series, 120 Series
			Gulfstream Aerospace	G-I, G-II, G-III VSCF, G-IV Series
			Lockheed	1329-23
			Learjet	24, 25, 28, 29, 31, 35, 36, 55
			Israel Aircraft Ltd	1121, 1123, 1124, 1125
			Aerospatiale	42 Series, 72 Series
			Pilatus Aircraft Ltd	PC-6 B2-H2 & -H4 Series, PC-7 & PC-7 MK H Series PC-9 Series, PC-12 Series
			Saab Aircraft	340 Series
Short Bros.	SD3-60			
Mitsubishi	MU-2B Series			

If your aircraft is not listed or for more details, please contact



HBL Power Systems Limited

Road # 10, Banjara Hills, Hyderabad - 500 034. INDIA

E-mail: contact@hbl.in

www.hbl.in